

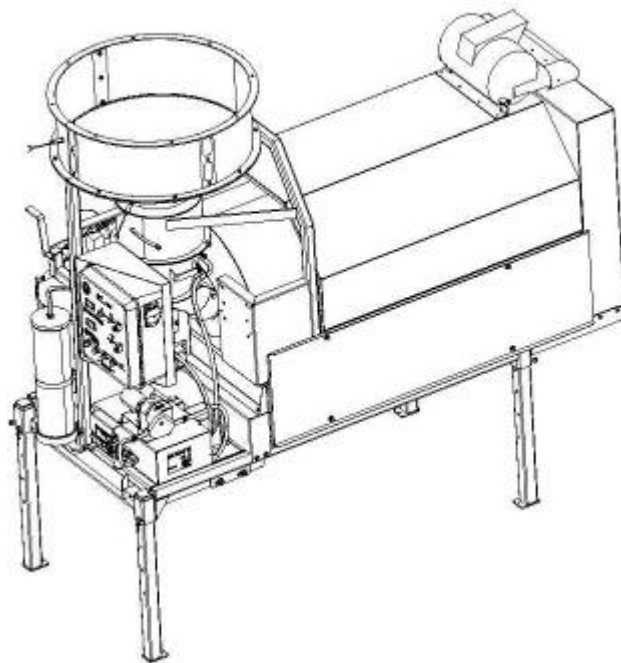

CONVEYORS INC

Quality product moving quality product

**Seed Dryer on Treater
Operator/Parts Manual**



How to Order Parts

1. Refer to the proper layout view for the area of the machine.
2. Find illustration of the part to be ordered.
3. Note the ITEM number in the balloon point to the part.
4. On the parts list, find the ITEM number listed in the table.
5. Find the Quantity, Part Number, and Description associated with the ITEM number for use when placing your order.

Paint

For matching paint, use Diamond Vogel IB5588 or equivalent.

Order supplies from

KSi Conveyors

454 N State Route 49
Cissna Park, IL 60924
Phone: 888-574-2668

Abbreviations used in Parts List

As.—Assembly
Bkt.—Bracket
Itm.—Item
LH—Left hand side
No.— Number
Opt—Optional equipment
Qty.—Quantity
RH—Right hand side

Seed Dryer Kit

21262-

00

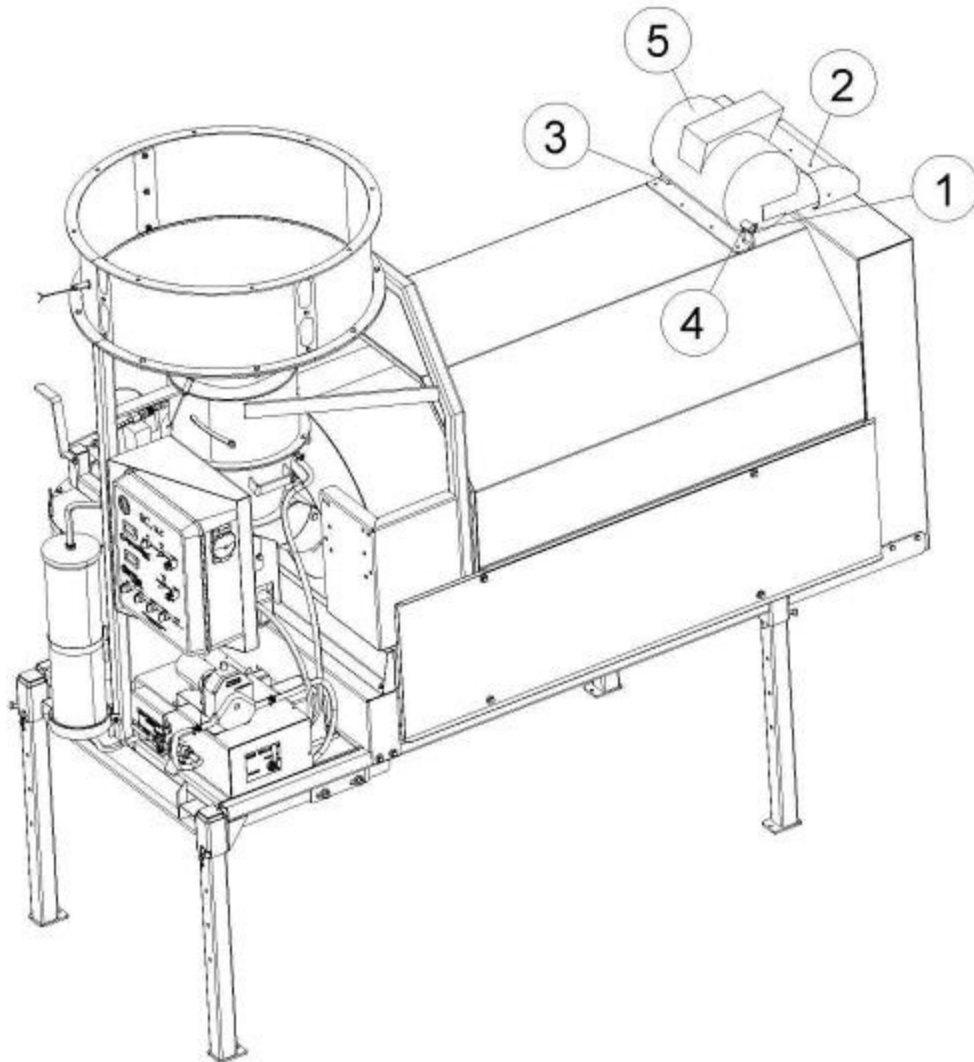

ITM	QTY	PART NO.	NAME
1	1	21287-01	ROD, FAN
2	1	21268-01	TRANSITION, FAN
3	1	21291-00	SUPPORT, FAN
4	1	24179-01	COTTER-HAIR PIN
5	1	24525-01	BLOWER FAN 3/4 HP
*	6	HB250Z050-C-5Z	BOLT SELF TAPPER (1/4 X 0.5)
*	4	HB312Z100-C-5Z	BOLT, (5/16 X 1.0) HEX BOLT
*	4	HN312Z-C-2Z	SERRATED FLANGE NUT(5/16)
*	1	21292-01	TEMPLATE

PICTURE OF INSTALLED FAN DRYER



ASSEMBLY INSTRUCTIONS

1. Center template, for air duct access hole, on treater guard so that solid flange is against discharge guard and cutout guide is on top of the treater discharge guard.
2. Mark outline of rectangular template cutout on treater guard.



IMPORTANT: Always wear eye protection when cutting or drilling.

3. Cut out (12.5" X 3.5") rectangle as marked on guard using cutoff wheel or similar tool.
4. Place fan on treater as shown on page 4. Assemble support (Items 1 & 3 on page 3) & transition (Item 2) to fan using self tapping screws.
5. Mark four hole locations (for Item3), remove fan assembly and drill 3/8" holes.
6. Remount fan assembly and complete final installation of mounting hardware.
7. Silicone around fan duct transition and top of guard if desired.